

PROLINE® MASTER COMMERCIAL-GRADE RESIDENTIAL



COMMERCIAL-GRADE HEATING ELEMENTS

- Dual 4500 watt elements for fast recovery and reliable operation.*
- Stainless steel upper & lower elements last longer than a standard copper element.

DYNACLEAN™ DIFFUSER DIP TUBE

- Helps reduce lime and sediment buildup and maximizes hot water output. Made from long-lasting PEX cross-linked polymer.

HIGH ENERGY FACTORS

- Eco-friendly non-CFC foam insulation, heat traps and other features combine to yield a higher Energy Factor that maximizes savings on operating costs.

COREGARD™ ANODE ROD

- Our anode rods have a stainless steel core that extends the life of the anode rod allowing superior tank protection far longer than standard anode rods.
- ProLine Master products have increased anode protection with either longer, or multiple anodes depending on model.

BLUE DIAMOND® GLASS COATING

- Provides superior corrosion resistance compared to industry standard glass lining.
- Blue Diamond® Glass coating blend is formulated in the same lab that creates the protection for our industry-leading commercial product line.

ENHANCED-FLOW BRASS DRAIN VALVE

- Our residential water heaters have a solid brass, tamper resistant, enhanced-flow, ball type, drain valve.
- Uses a standard female hose fitting that allows for fast and easy draining during maintenance.

* Standard wattage, other options available

- Designed for easy operation, this valve includes an integral screwdriver slot that features a ¼ turn (open/close) radius, which not only permits full straight-through water flow but also a quick and positive shut off.

CODE COMPLIANCE

- Meets UBC and ICC National Codes and listed with CEC.
- Complies with the Federal Energy Conservation Standards effective April 16, 2015, in accordance with the Energy Policy and Conservation Act (EPCA), as amended.

APPROVED FOR MANUFACTURED HOUSING

- All residential electric water heaters are compliant with HUD Standards for mobile homes/manufactured housing.

CERTIFIED TO UL 174 FOR HOUSEHOLD ELECTRIC WATER HEATERS

CSA CERTIFIED AND ASME RATED T&P RELIEF VALVE

DESIGN-LISTED BY UNDERWRITERS LABORATORIES

- Certified at 300 psi test pressure and 150 psi working pressure.
- Listed according to UL 174 standards governing storage tank-type electric water heaters.

8-YEAR LIMITED TANK AND PARTS WARRANTY



Model Number	Gallon Capacity	First Hour Rating Gallon	Energy Factor	Recovery @ 90°F Rise Gallon Per Hour	Element Wattage 240V		Dimensions in Inches			Approx. Shipping Weight (lbs)
					Standard	Maximum	A	B	C	
Tall Models										
HNT 40	40	50	0.95	21	4500	6000	61-1/2	53-1/4	18	118
HNT 50	50	73	0.95	21	4500	6000	60-1/2	51-1/4	20-1/2	125
HNT 55	55	76	0.94	21	4500	6000	56-1/2	48-1/2	24	145
Short Models										
HNS 40	40	55	0.95	21	4500	6000	49-3/4	40-3/4	20-1/2	109
HNS 50	50	62	0.95	21	4500	6000	49-1/4	40-3/8	23	161

Male 3/4" water connections on 8" center.

Dimensions and specifications subject to change without notice in accordance with our policy of continuous product improvement.

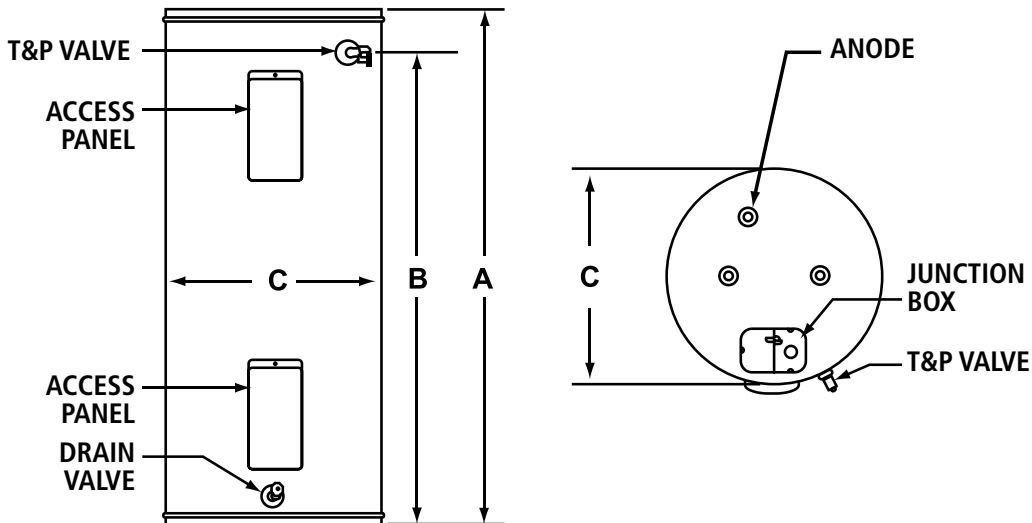

For technical information call 800-527-1953. A. O. Smith Corporation reserves the right to make product changes or improvements without prior notice.